

Specifications*

MODEL		SX25
ENGINE (DIESEL)		
Model		3C100LWH-E2
Typ		3-cylinder water-cooled diesel engine, STAGE V
Displacement	cc	1007
Gross power	DIN hp/ (kW)	24.5 (18.3)
Torque	Nm @ rpm.	57.0 @ 2500
Rated speed	rpm.	3200
Fuel tank capacity	l.	25.5
TRANSMISSION		
Transmission		Hydrostatic
Range		F/R 2
Driving speed	Forward	0 - 16.6
	Reverse	0 - 11.2
4-wheel drive		mechanical
Differential lock		mechanical
Brake		wet disc
TIRES		
Industrial/ terra	Front	18x8,50-10 R4
	Rear	26x12,00-12 R4
Turf	Front	18x8,50-10 R3
	Rear	26x12,00-12 R3
PTO		
Power	hp	20.5
Rear	l/min.	540
Mid	l/min.	2000
Rear		option
HYDRAULIC SYSTEM		
Pump capacity	l/min.	24.6
Steering		Hydraulic power steering
Control valve		option: 1 x double acting rear
3-point hitch		Category I
Max. lifting capacity	kg	715
DIMENSIONS		
Length	mm	2800
Width	mm	1183
Height	mm	2285
Ground clearance	mm	185
Wheel base	mm	1400
Weight incl. ROPS	(kg)	700

*We reserve the right to discontinue models or change specifications without notice.

SUBCOMPACT TRACTOR

SX25

SHIBAURA



Important information

* Improper use of any product may cause serious or fatal injury. Read carefully the operating and safety instructions in your owners manual before use.



SHIBAURA EUROPE BV

Begonialaan 7

NL - 6851 TE Huissen

T. 0031 (0)26 326 9999

F. 0031 (0)26 326 9990

E. info@shibaaura.com

I. www.shibaaura.com

Dealer:

LEVERS



Various levers (HST High-Low range shift, PTO select/clutch, etc.) are arranged either side of the operator seat in an optimal layout to ensure comfortable operation.

DASHBOARD



Standard power steering, easy-to-read dashboard and a completely flat floor.

ENGINE

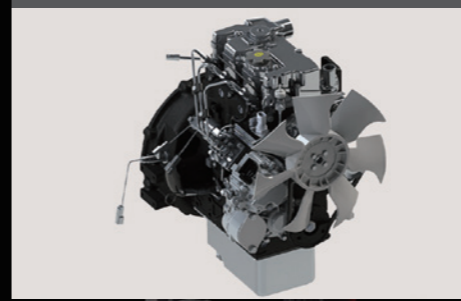

Reliable and fuel-efficient diesel engine, STAGE V.

OPTIONAL IMPLEMENTS

CABIN



The SX25 can be equipped with a cabin. Height: 196,5 cm.

FRONTLOADER



SPECIFICATIONS

Maximum lift height to pivot pin: 1810 mm
 Maximum lift height under level bucket: 1638 mm
 Clearance with bucket dumped: 1298 mm
 Maximum dump angle: 45°
 Maximum rollback angle: 27°
 Dig depth: 130 mm
 Breakout force at bucket pivot pin: 604 kg
 Lift capacity to maximum height : 306.3 kg

REAR PTO & 3-POINT HITCH



Combined with the rear PTO and category-1 three-point hitch, a variety of implements and attachments can be fitted according to the type of works.

MOTORHOOD



An extremely wide-opening hood provides good serviceability to the engine, air filter, and electrical components.



MIDMOUNTED MOWER



SPECIFICATIONS

Mowing width: 1372 / 1524 mm
 Weight: 100 / 113 kg
 Mowing height adjustable in 7 steps: 25-102 mm

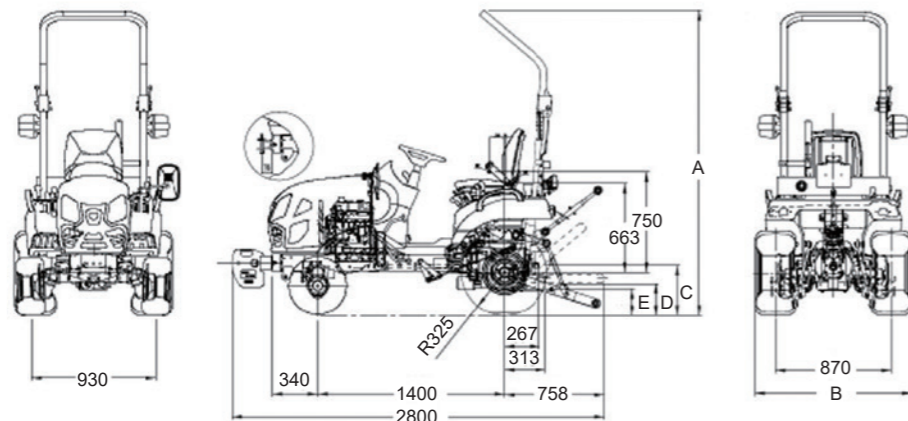

	Turf	Industrial
FRONT	18x8.5-10 R3	18x8.5-10 R4
REAR	26x12.00-12 R3	26x12.00-12 R4
A	2280	2285
B	1183	1183
C	370	375
D	234	239
E	195	200

TIRES



Turf tire & Industrial/ Terra tire.

FRONTLIFT & FRONT PTO



Double acting frontlift with A-frame.